

NOTES:

1. P2 (MBS P/N: 255-0830): DB9 PLUG IS AN OPTIONAL ITEM W/ A 3 FT. CABLE (OTHER CABLE LENGTHS AVAILABLE UPON REQUEST)
2. J2: DB9 CONTROL INTERFACE PINOUT SEE SHEET 2 OF THIS DRAWING FOR SCHEMATIC

PIN	NAME	DESCRIPTION
1	- COMMAND	INPUT: TORQUE COMMAND MINUS (GND REF. FOR PIN 2)
2	+ COMMAND	INPUT: TORQUE COMMAND POSITIVE
3	PWR GND	OPTIONAL (i.e. SIGNAL SHIELD)
4	- DIGITAL OUT	GND REF FOR TEMP FAULT SIGNAL. SEE NOTE 3
5	+ DIGITAL OUT	OUTPUT: DIGITAL (HI / LOW). SEE NOTE 3
6	+ SPEED	OUTPUT: SPEED OUTPUT (0-4 VDC)
7	- SPEED	OUTPUT: GND REF FOR PIN 6
8	AUTO/MANUAL	INPUT +5 VDC DURING POWER UP = AUTO-DECOG (MBZ ONLY)
9	MAN DE-COGG	GROUND PIN 4 & 9 W/ MOMENTARY SWITCH TO ACTIVATE

3. ** TEMP FAULT SIGNAL, SOFTWARE V2.9 AND LATER, ONLY WORKS WITH MBS TEMPERATURE SENSOR (MBS PART# MBS-IR-1). WHEN MAX DRAG RING TEMPERATURE IS REACHED, SENSOR SIGNALS CONTROLLER TO CUT POWER TO BRAKE; SIGNAL GOES FROM LOW TO HIGH.

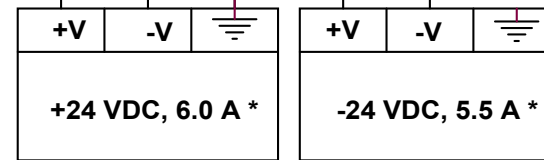



*POWER SUPPLIES ARE NOT INCLUDED WITH THE PURCHASE OF BRAKE AND CONTROLLER.

*24 VDC, 6.5A, POWER SUPPLIES MAY BE PURCHASED FROM MBS (P/N: EP7136)

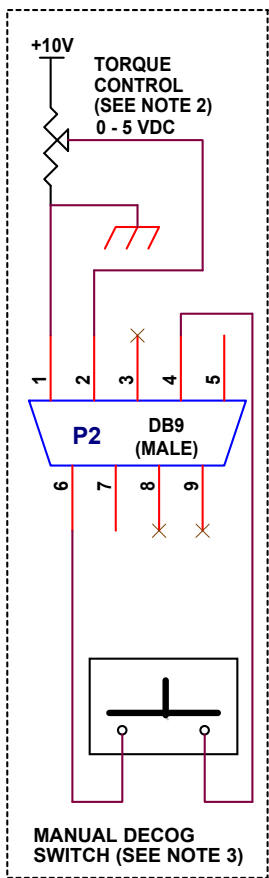
	<p>THE INFORMATION DISCLOSED HEREIN IS THE EXCLUSIVE PROPERTY OF</p> <h2 style="margin: 0;">MAGNETIC BRAKE SYSTEMS</h2> <p>OR MAY CONTAIN PROPRIETARY RIGHTS OF OTHERS AND IS NOT TO BE USED OR DISCLOSED TO OTHERS WITHOUT THE WRITTEN CONSENT OF THE ABOVE</p>	
	<p>09/05/18</p>	<p>INTERFACE - MBL/MBZ, 0-5 VDC TORQUE CMD SIGNAL</p>



TYPICAL EXTERNAL CONTROL APPLICATION FOR MBL/MBZ BRAKE.
A MOMENTARY SWITCH IS NOT APPLICABLE FOR THE MBL MODEL BRAKE. (SEE NOTES)

 Analog
  Digital
  Power

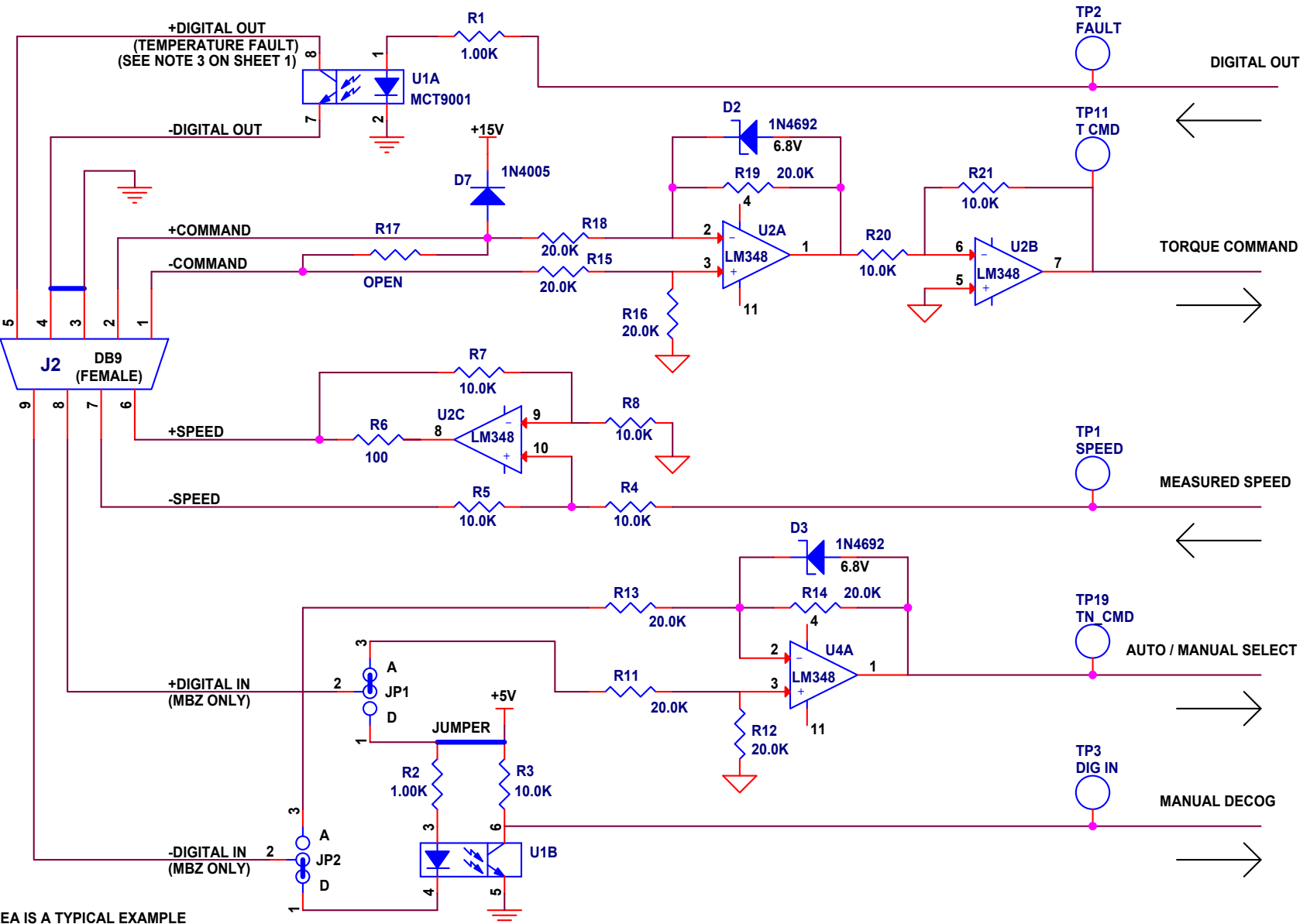

- NOTES:**
1. SCHEMATIC IN THE DASHED AREA IS A TYPICAL EXAMPLE OF A CONTROL APPLICATION FOR THE BRAKE CONTROL MODULE. SECTION IN DASHED LINE IS PROVIDED BY THE CUSTOMER.
 2. A DC VOLTAGE SIGNAL CONTROLS THE TORQUE OF THE BRAKE. THE TORQUE SCALE FACTOR FOR THE BRAKE IS MARKED ON THE DATA SHEET FOR THE BRAKE.
 3. MANUAL DECOG SWITCH (MBZ MODELS ONLY) - A MOMENTARY SWITCH, NORMALLY OPEN. CLOSURE WILL INITIATE THE MANUAL DECOG CYCLE IN THE BRAKE CONTROL. SWITCH MAY BE PURCHASED FROM MBS (P/N: EP7869)
 4. FOR SOFTWARE VERSION 2.9 AND LATER, MANUAL DECOG IS THE DEFAULT SETTING FOR MBZ MODEL BRAKES. SUPPLYING +5VDC ON PIN 8 WHILE POWERING ON SYSTEM WILL SELECT AUTO DECOG.

	THE INFORMATION DISCLOSED HEREIN IS THE EXCLUSIVE PROPERTY OF MAGNETIC BRAKE SYSTEMS	
	OR MAY CONTAIN PROPRIETARY RIGHTS OF OTHERS AND IS NOT TO BE USED OR DISCLOSED TO OTHERS WITHOUT THE WRITTEN CONSENT OF THE ABOVE	
09/05/2018	INTERFACE - MBL/MBZ, 0-5 VDC TORQUE CMD SIGNAL	SHEET 2 OF 2 200-0804-03

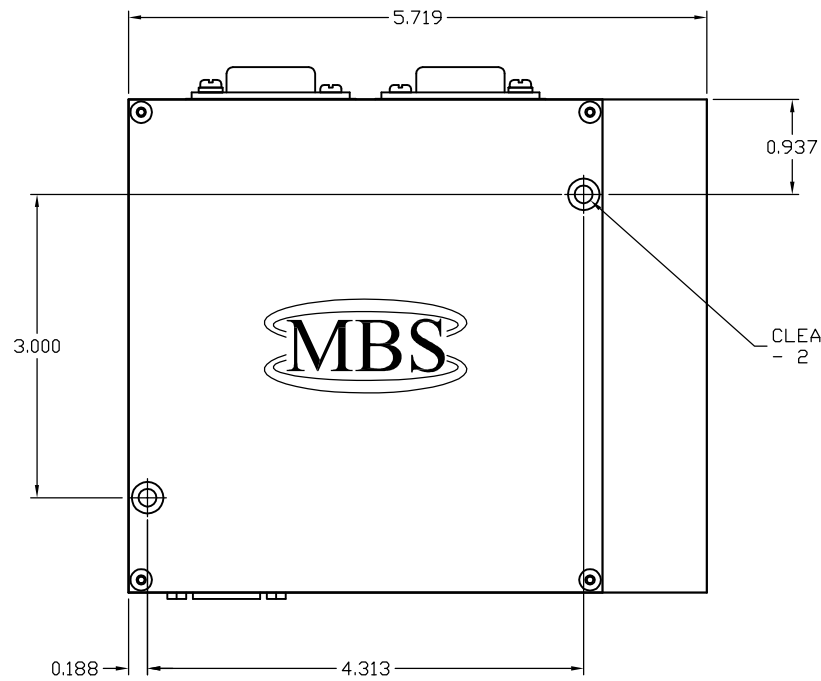

CLEARANCE FOR A #8 SCREW
- 2 PLACES

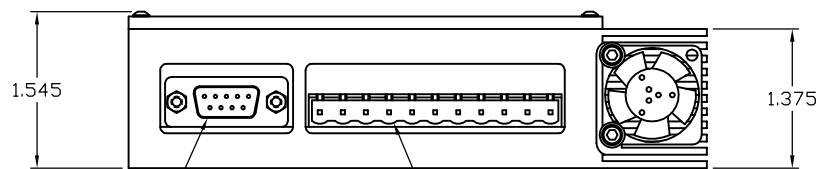
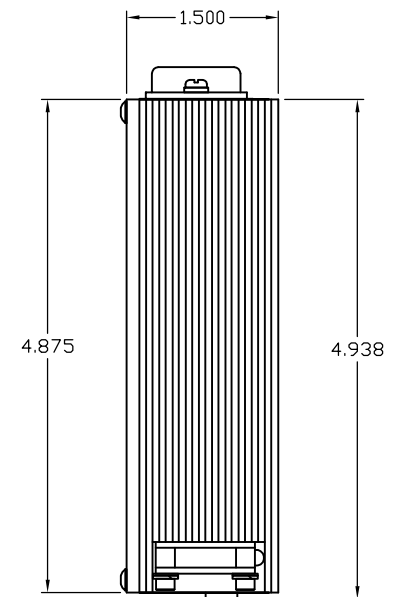

J2 (FEMALE) DB9

J1 (MALE) EURO STYLE (PHOENIX CONNECTOR)

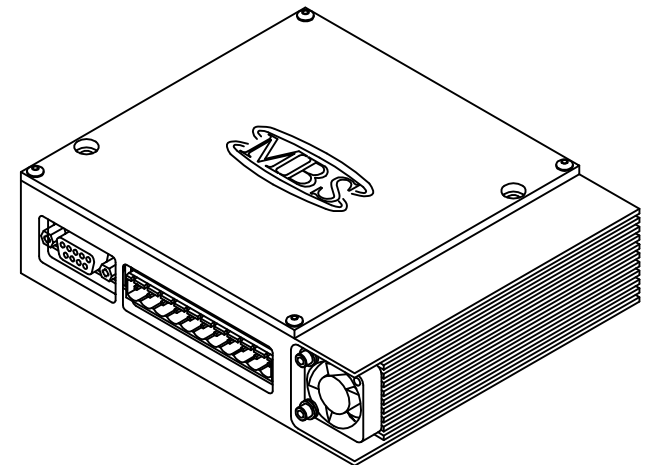

NOTES:

1.

- UNLESS OTHERWISE SPECIFIED
 1. DIMENSIONS ARE PER ANSI Y14.5-1973
 2. SURFACE ROUGHNESS PER ANSI B46.1-1978
 3. LINEAR DIMENSIONS IN INCHES
 4. LINEAR TOLERANCES:
 X ± .05, XX ± .02, XXX ± .005
 5. ANGULAR TOLERANCES:
 X ± 5°, XX ± 5°
 6. MACHINED SURFACES:
 1 AND 1 ALL PLANES .002/INCH
 DIAMETERS WITHIN .005 TIR
 MAXIMUM SURFACE ROUGHNESS √ 32
 7. BREAK EDGES .01 TO .02
 8. FILLETS R0.02 MAX



THE INFORMATION DISCLOSED HEREIN IS THE EXCLUSIVE PROPERTY OF
MAGNETIC BRAKE SYSTEMS
 4725 CALLE QUETZAL, CAMARILLO, CA 93012
 OR MAY CONTAIN PROPRIETARY RIGHTS OF OTHERS AND IS NOT TO BE USED OR
 DISCLOSED TO OTHERS WITHOUT THE WRITTEN CONSENT OF THE ABOVE

ASSY. - CONTROLLER,
 MBL/MBZ BRAKE

SH 1 OF 1
 255-0410B